

IP-65 Rated Outdoor Non-Touch Super Slim Wallmount Digital Signage .

Durable Outdoor Digital Signage with IP-65 Rating,
Available in 21" to 55" Sizes.

Slim. Weatherproof. Stunning Visuals.



HARDWARE TOP FEATURES



HARDWARE TOP FEATURES



Wi-Fi Support

Enjoy versatile connectivity options with built-in Wi-Fi and Ethernet, allowing for seamless integration, remote content management, and reliable performance in any network environment.



Advanced Thermal Management

Ensures optimal performance by efficiently dissipating heat to prevent overheating.



Super Slim and Quiet Design

Sleek, thin profile with silent operation for a modern, discreet look.



Sturdy IP65 Rated Enclosure

Provides superior weatherproofing for reliable performance in outdoor environments.



3500 nits High Brightness

Delivers vivid, clear visuals even in bright sunlight.



Anti-Reflective Coating

Reduces glare for clearer, more readable content in bright conditions.



Wide Range of Sizes

Choose from a range of sizes to fit your specific needs and applications.



VESA Standard Mount Included

Includes VESA Standard Mount for easy and secure wall installation.



Energy-Efficient Operation

Designed to minimize power consumption while delivering high performance.

PRISM | Hardware Brochure

Advanced Thermal Management

Our digital signage incorporates sophisticated thermal management technology designed to maintain peak performance by effectively dissipating heat. This system ensures that the display remains cool under heavy use and in high-temperature environments, preventing overheating and potential damage. By managing heat efficiently, it enhances the longevity and reliability of the signage, making it suitable for demanding applications and extended operational hours.

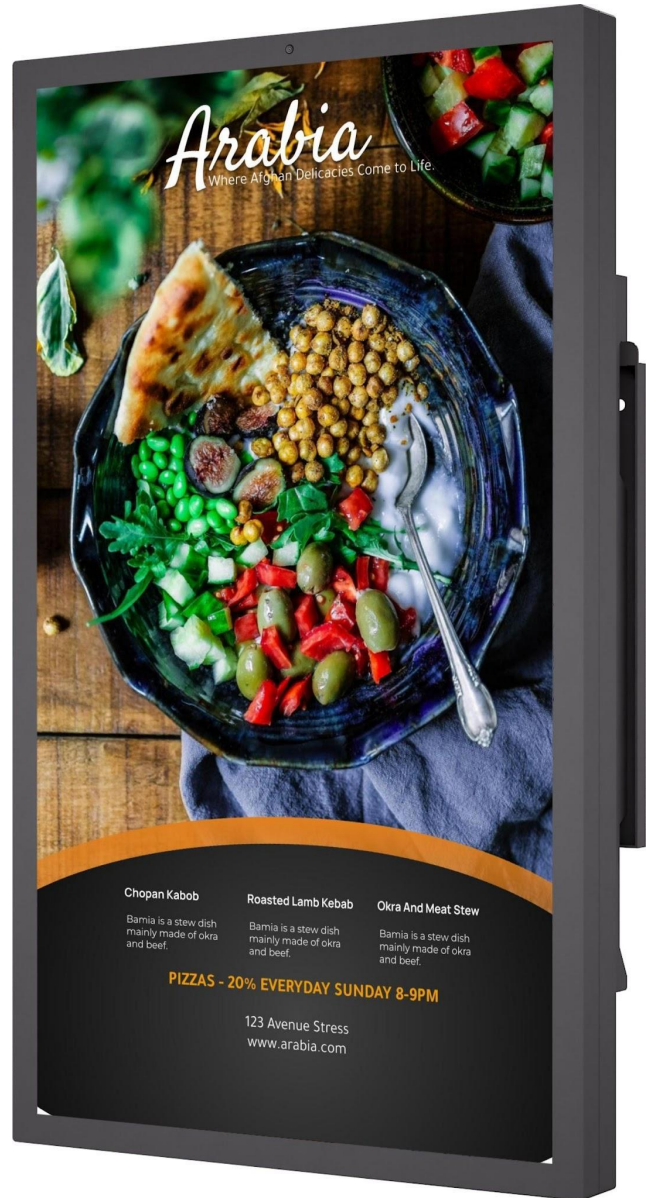

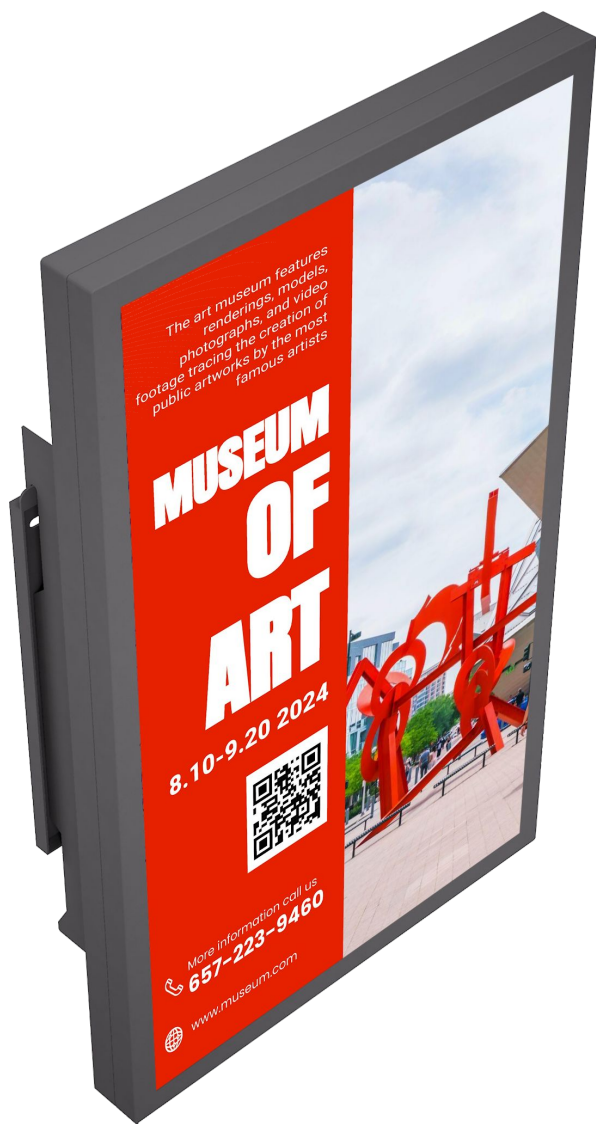

Super Slim and Quiet Design

This digital signage features a remarkably slim profile that combines elegance with functionality, making it a visually appealing choice for any space. Its ultra-thin design ensures a modern, unobtrusive presence, while its silent operation guarantees minimal noise, creating a seamless and distraction-free experience. Ideal for environments where both aesthetics and a quiet atmosphere are crucial, this signage delivers on both fronts.



Wi-Fi and Ethernet Connectivity

Benefit from advanced connectivity options with our built-in Wi-Fi and Ethernet capabilities. This feature allows for effortless integration into your existing network, providing flexible and reliable connections. Manage and update content remotely with ease, ensuring smooth operation and adaptability in any network environment. Whether you're implementing the signage in a busy commercial setting or a dynamic public space, this robust connectivity ensures consistent performance and simplifies content management.

Energy-Efficient Operation

Energy-Efficient Operation: Our digital signage is engineered for optimal energy efficiency, reducing power consumption without compromising performance. This design not only lowers operational costs but also supports eco-friendly practices by minimizing energy use. Ideal for long-term use in both commercial and public settings, it combines high functionality with reduced environmental impact.





Sturdy IP65 Rated Enclosure

Designed for exceptional durability, this enclosure offers superior weatherproofing with its IP65 rating, ensuring reliable performance in harsh outdoor conditions. It effectively protects the digital signage from dust, moisture, and other environmental factors, making it an ideal choice for high-traffic areas and challenging weather environments. With this robust enclosure, you can trust in the longevity and consistent operation of your signage, regardless of the elements.



Tasty
ALFAHAM
Where Afghan Delicacies Come to Life.

 <p>Chopan Kabob Bamia is a stew dish mainly made of okra and beef.</p>	 <p>Roasted Lamb Kebab Bamia is a stew dish mainly made of okra and beef.</p>	 <p>Okra And Meat Stew Bamia is a stew dish mainly made of okra and beef.</p>
---	---	---

SAVE UP TO
50%



3500 Nits High Brightness

Experience exceptional clarity and vibrancy with 3500 nits of brightness. This high brightness level ensures that your visuals are crisp and easily readable, even in direct sunlight or other bright environments. Perfect for outdoor settings and high-visibility applications, it guarantees that your content stands out with maximum impact and clarity.

Anti-Reflective Coating

Featuring a state-of-the-art anti-reflective coating, this digital signage ensures optimal visibility and readability in various lighting conditions. The coating effectively reduces glare and reflections, allowing for clearer and more detailed content display even in bright sunlight or high-contrast environments. This enhancement not only improves the viewer's experience by providing a more comfortable and uninterrupted view but also ensures that your messages and visuals remain sharp and impactful, regardless of external lighting challenges.

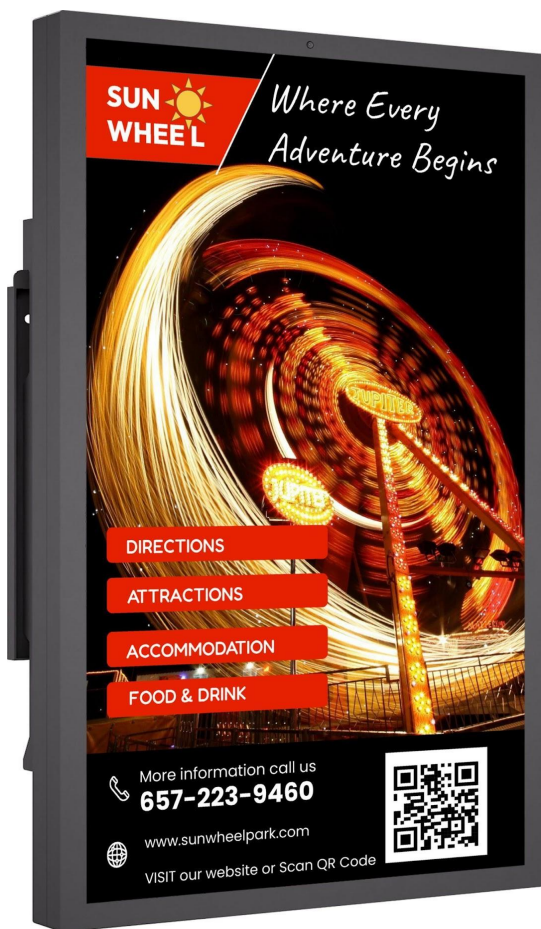

AG GLASS



REGULAR GLASS



Wide Range of Sizes

Wide Range of Sizes: Our digital signage is offered in a diverse selection of sizes to accommodate various needs and applications. From compact models suitable for smaller spaces to larger screens ideal for high-visibility environments, our range ensures you can find the perfect size for your specific requirements. This flexibility allows you to tailor the signage to your space, enhancing its effectiveness and integration within any setting

VESA Standard Mount Included

This digital signage comes with a VESA standard mount, making installation straightforward and secure. The included mount ensures a stable and reliable attachment to any wall, allowing for easy setup and adjustment. This feature provides flexibility in positioning your display, ensuring it is securely fastened and perfectly aligned for optimal viewing and functionality



Outdoor Non-Touch Super Slim Wallmount Digital Signage

Height: 1284 mm (50.55 inches)

Thickness: 175 mm (6.88 inches)

Width: 752 mm (29.60 inches)

175 mm
(6.88 inches)

752 mm
(29.60 inches)

1284 mm
(50.55 inches)

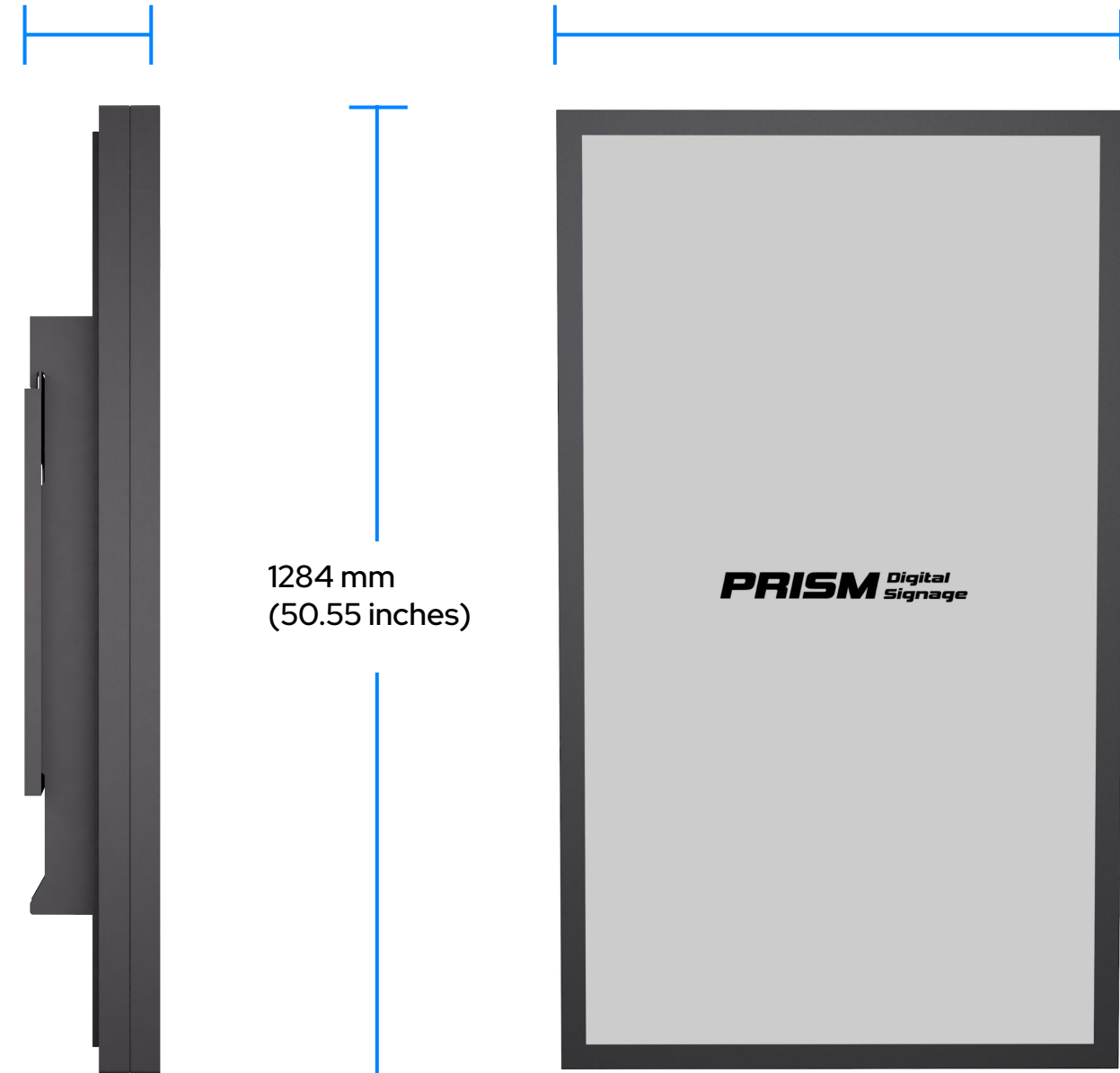

PRISM

Shop online with confidence. To check out an online demo of our software, visit our YouTube page.

<https://www.youtube.com/@PRISMDigitalSignage>